

buki di tarea 1

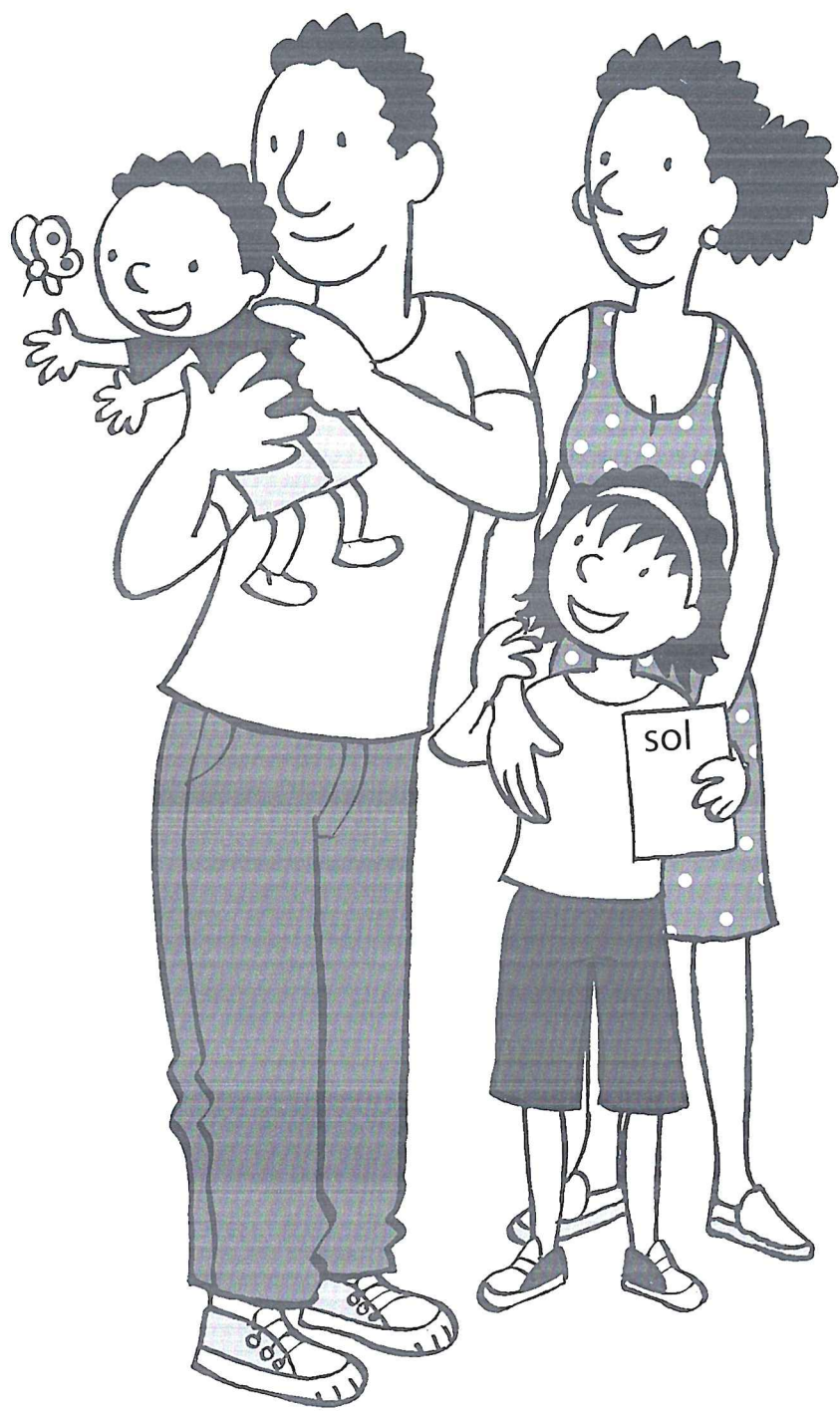

Método pa siña lesa na Papiamentu





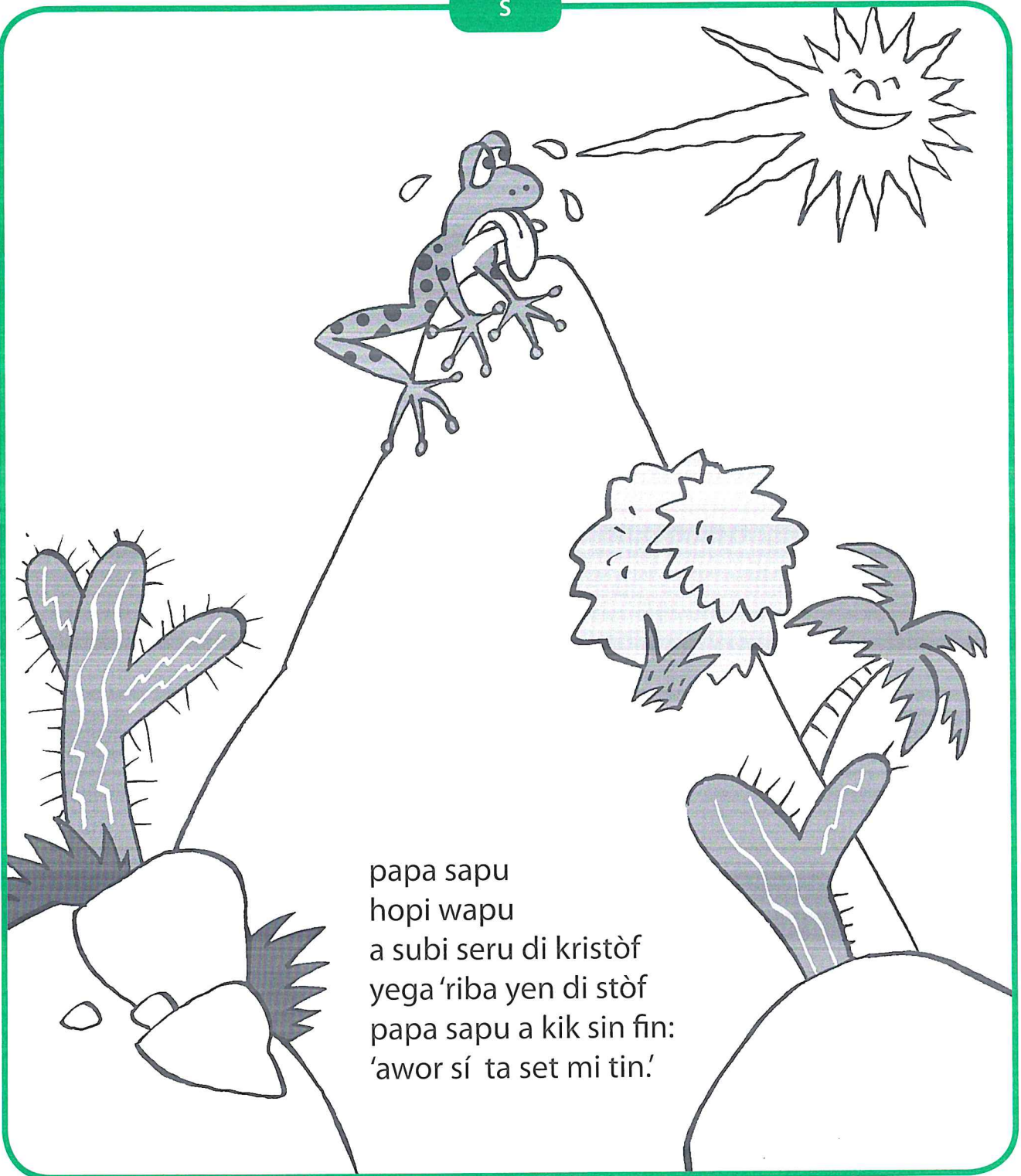

papa sapu
hopi wapu
a subi seru di kristòf
yega 'riba yen di stòf
papa sapu a kik sin fin:
'awor sí ta set mi tin.'

S

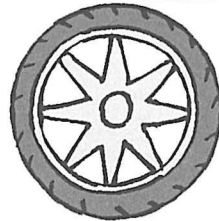
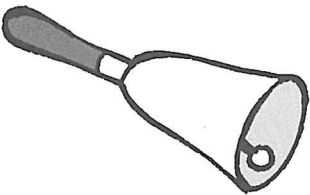
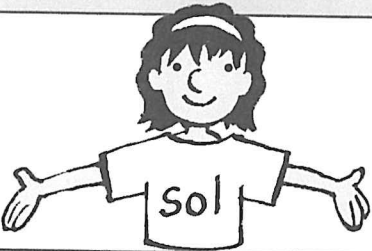
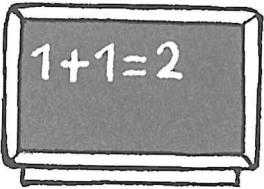
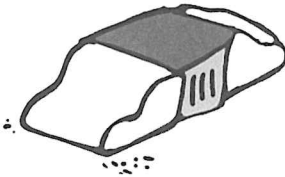
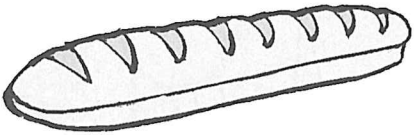
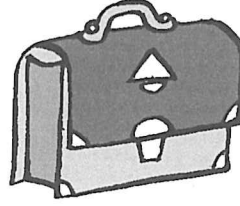
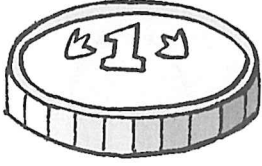

ber

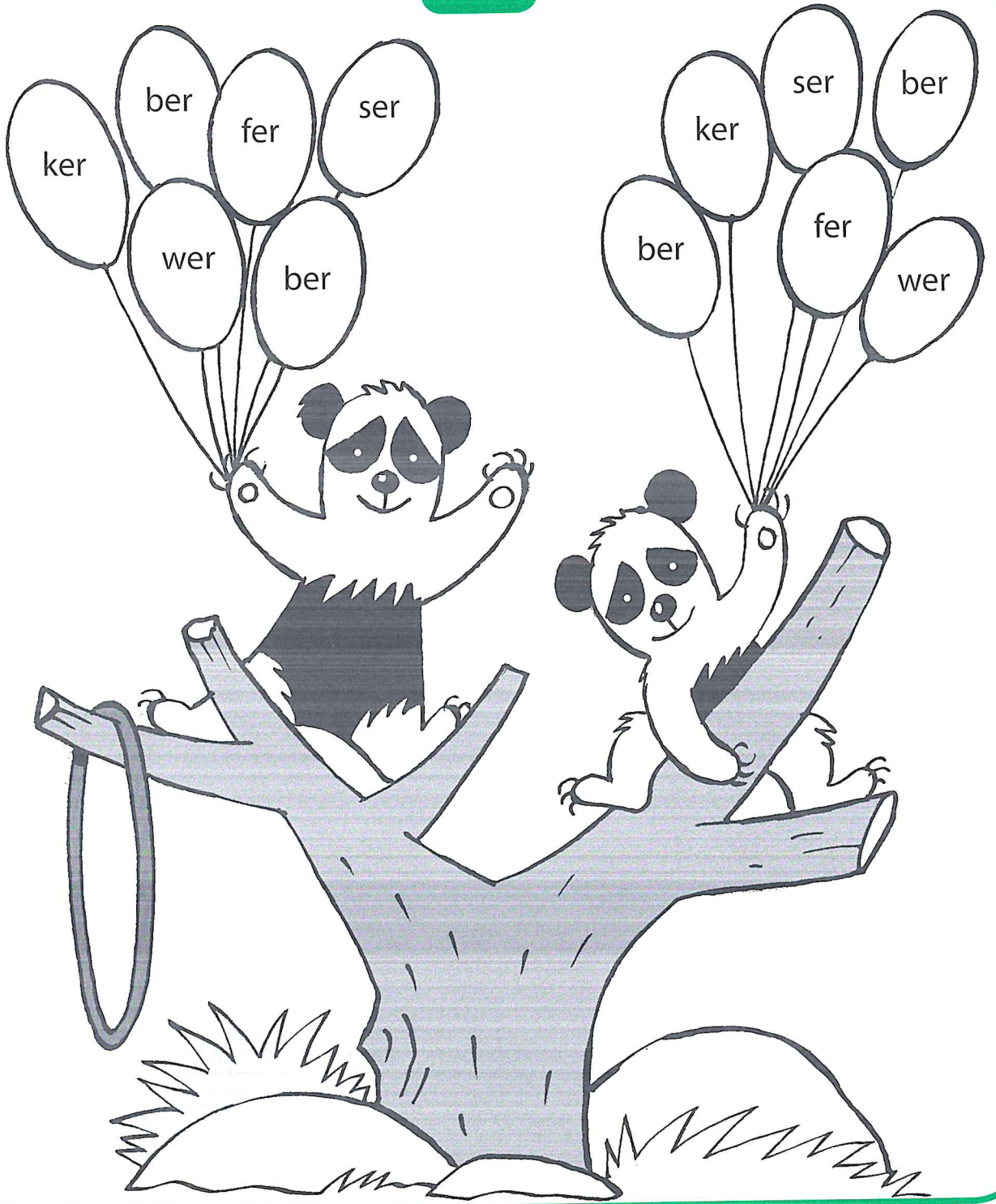

b

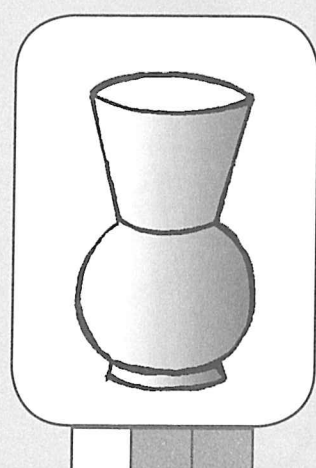
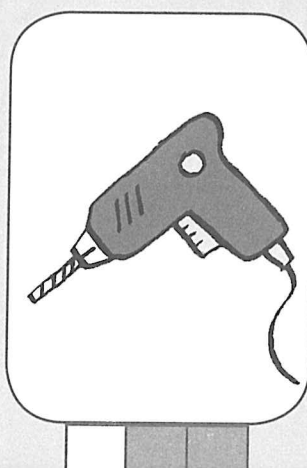
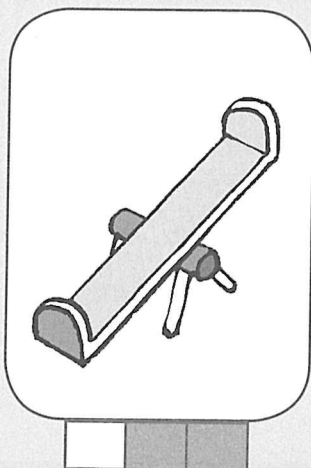
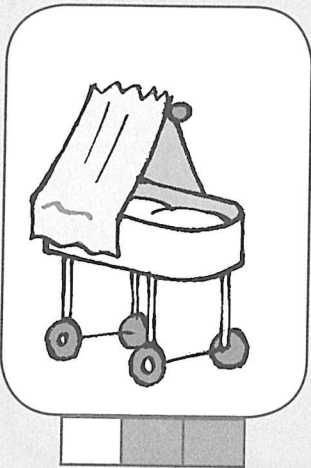
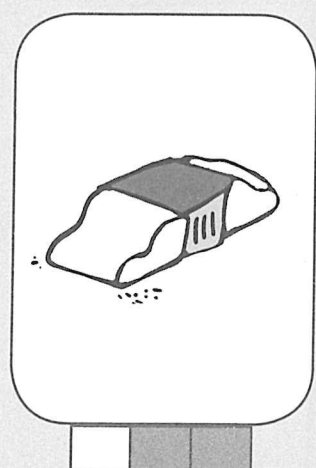
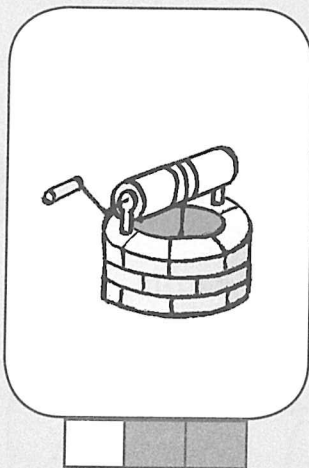
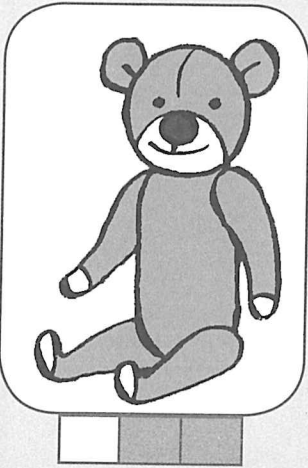
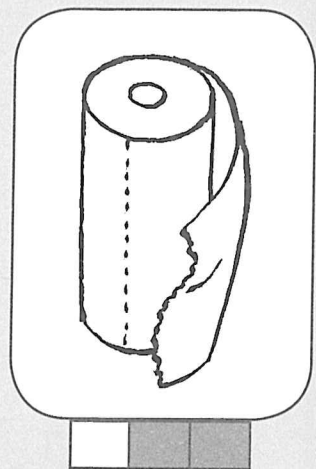
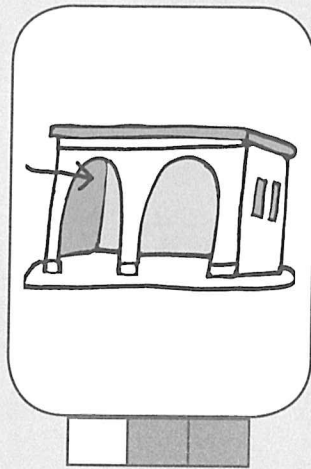
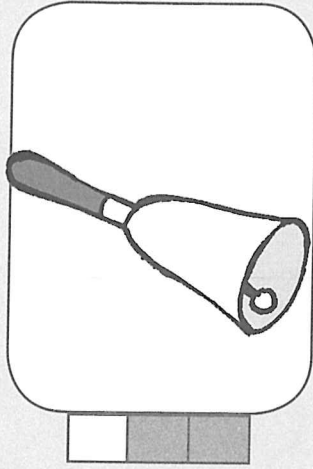

un



ui



un

un



uf



ku



an



ui



un



un

uf



b

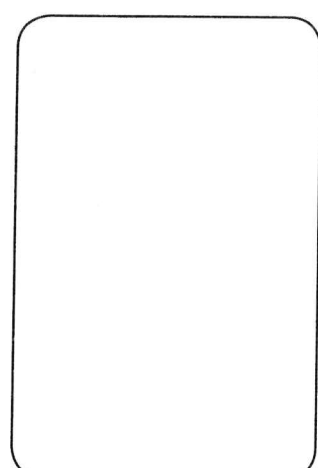
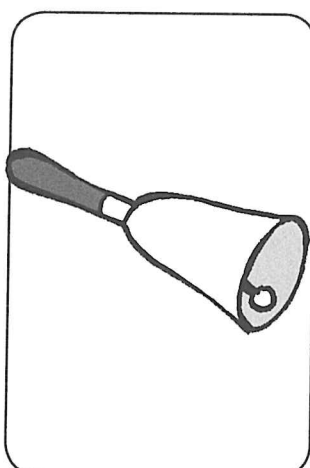
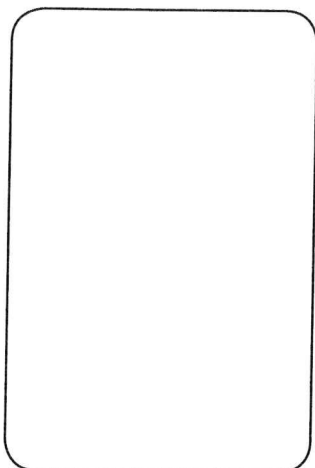
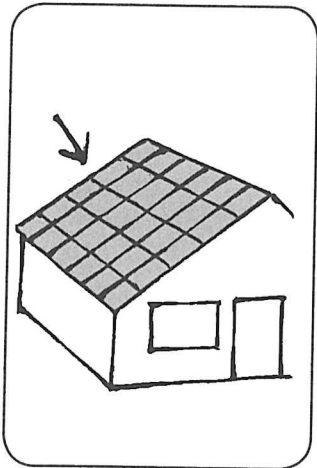
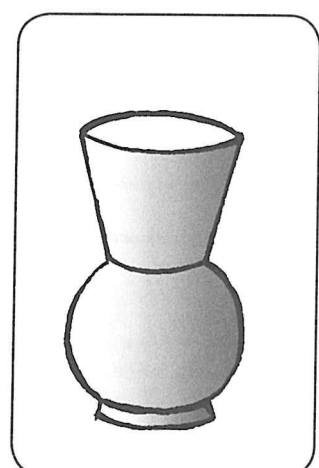
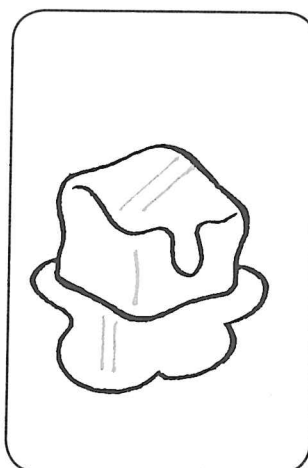
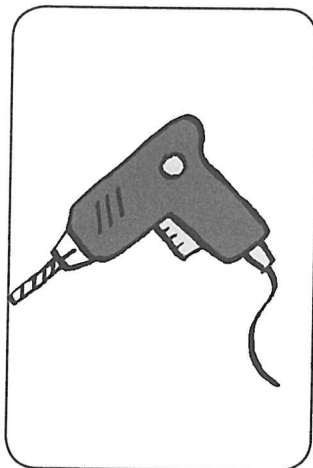
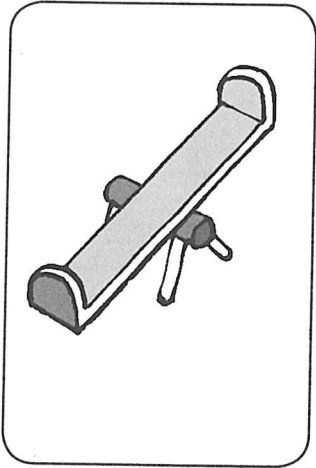
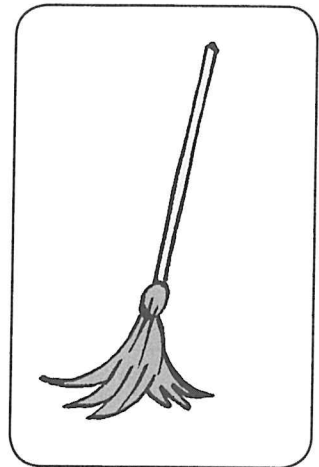
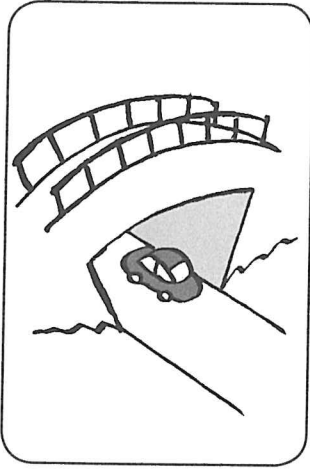

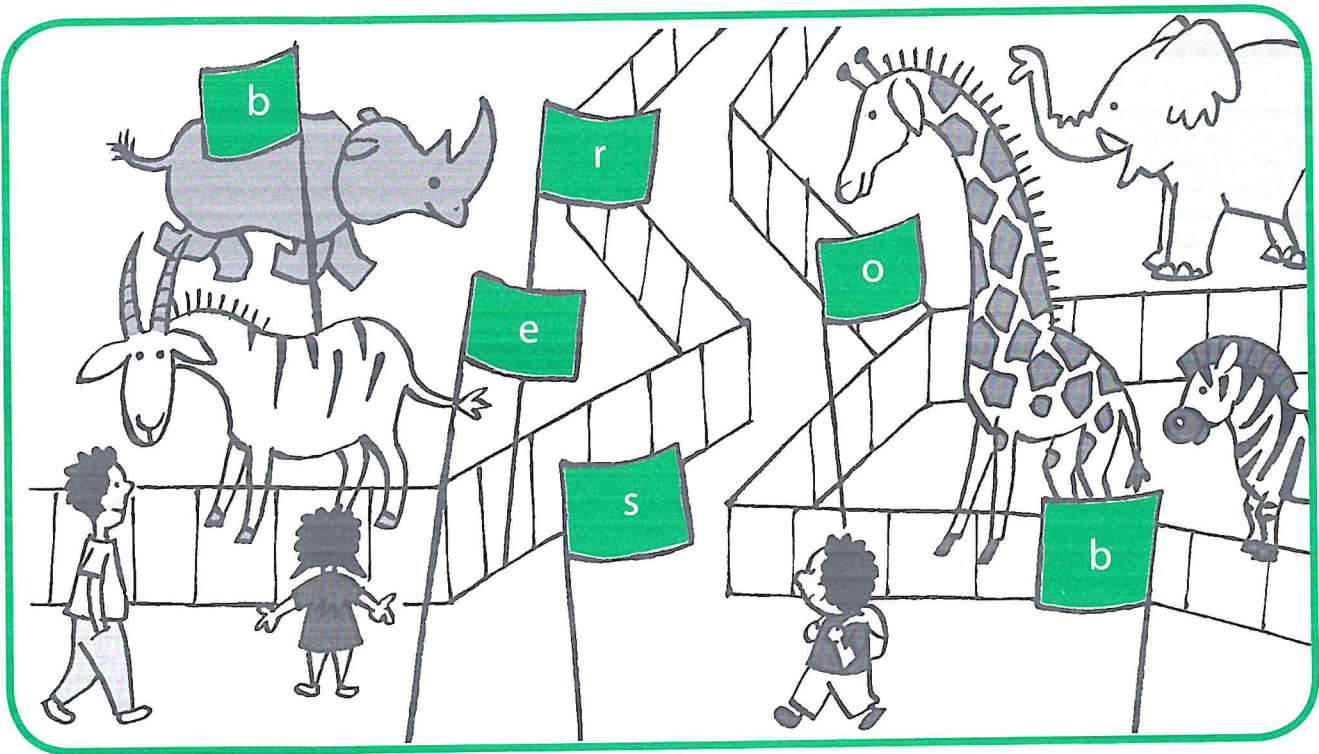
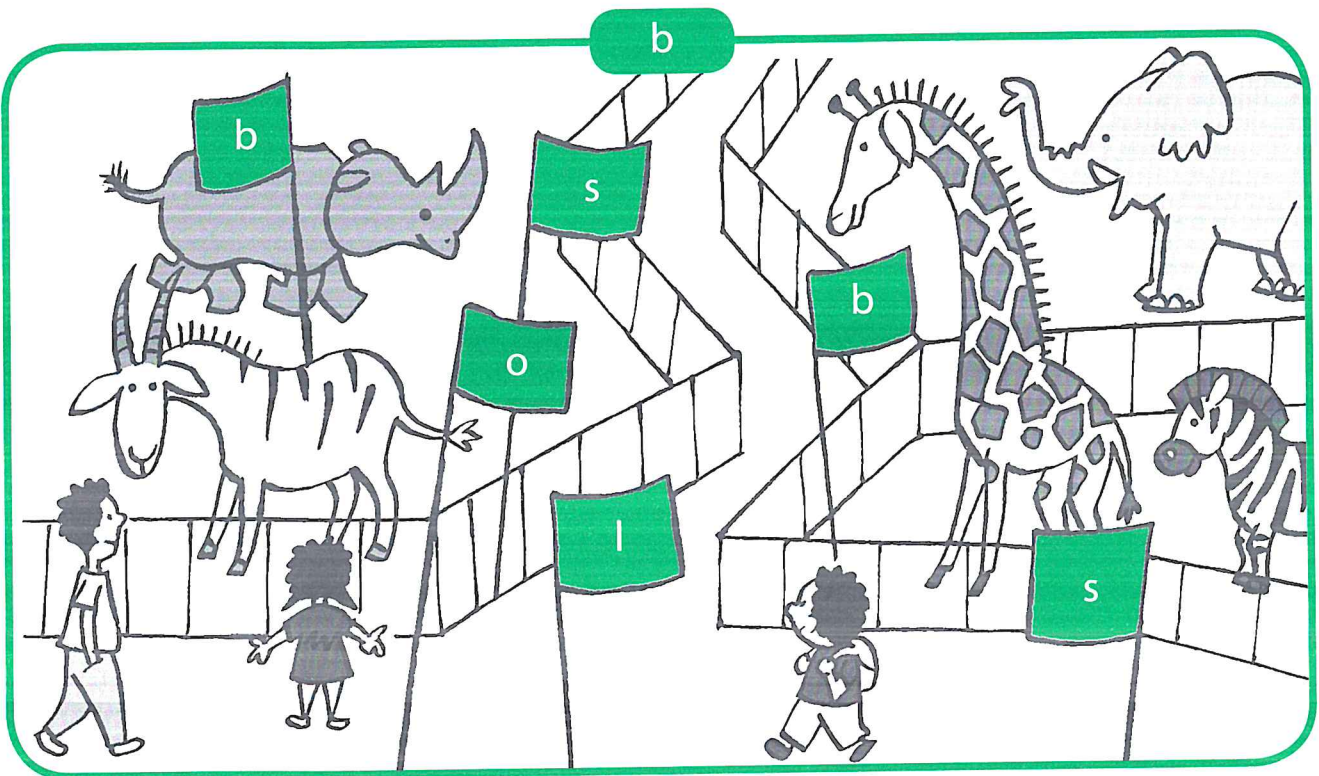
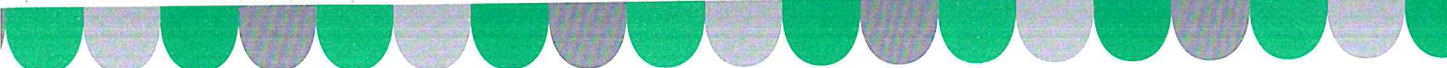

sol

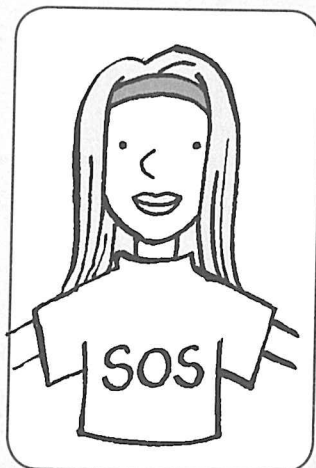
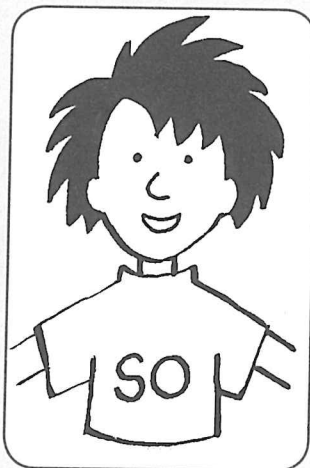
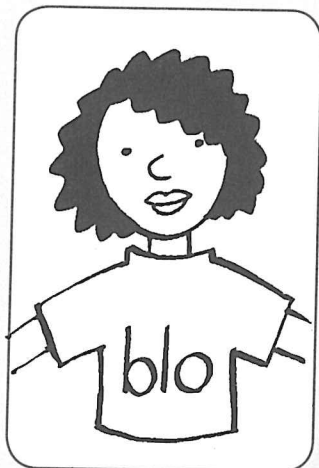
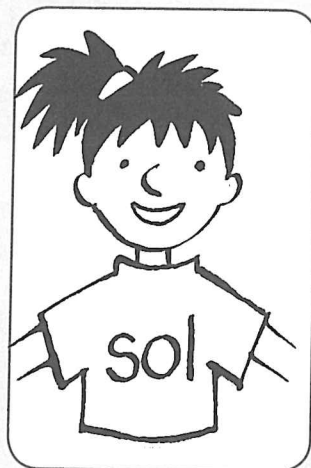
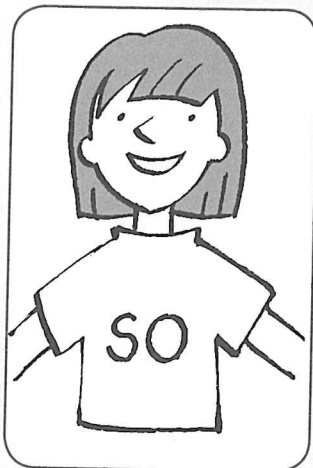

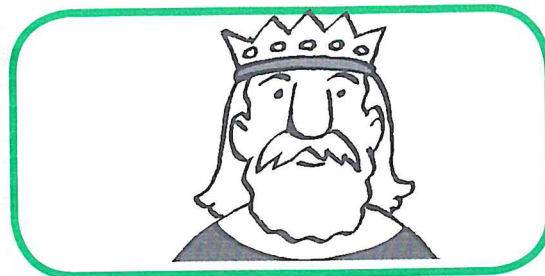
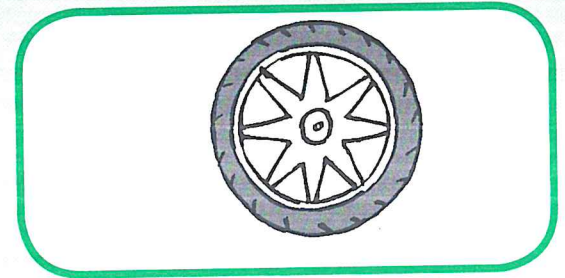
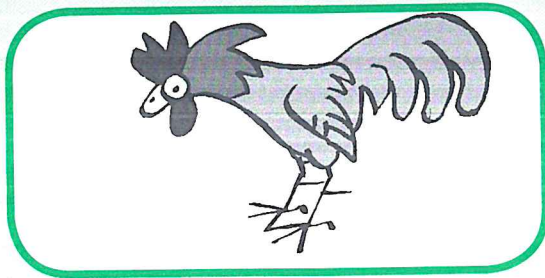
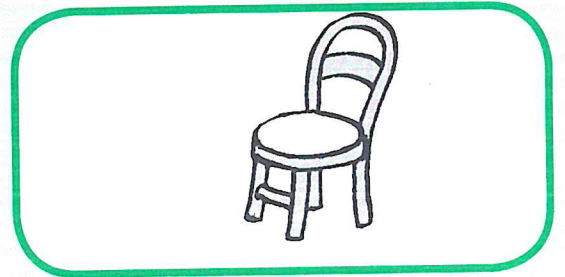
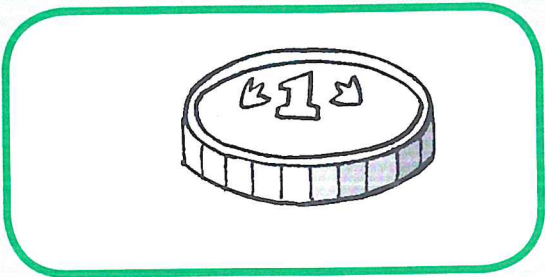

S

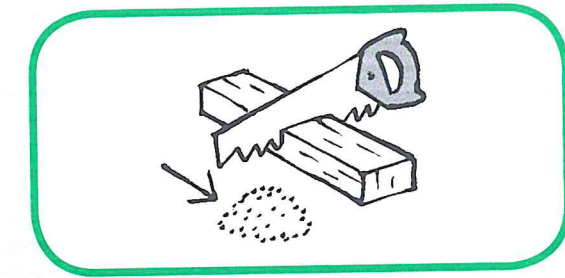
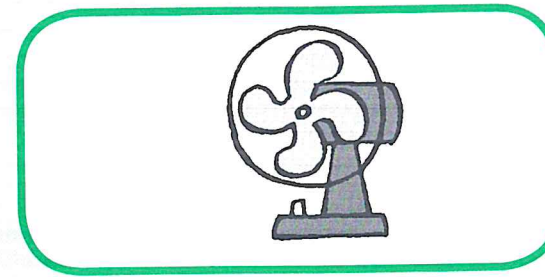
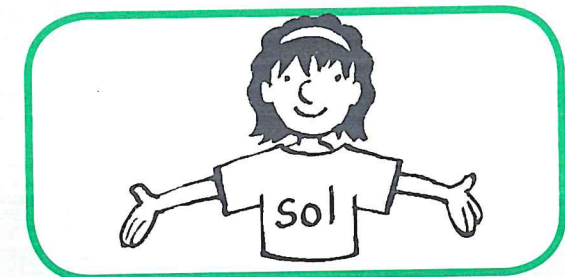
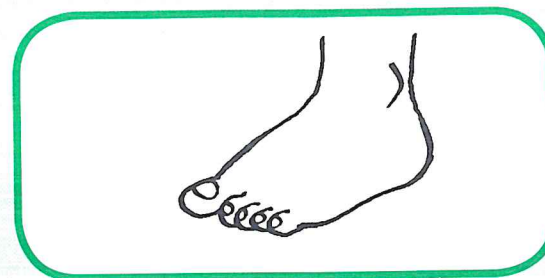
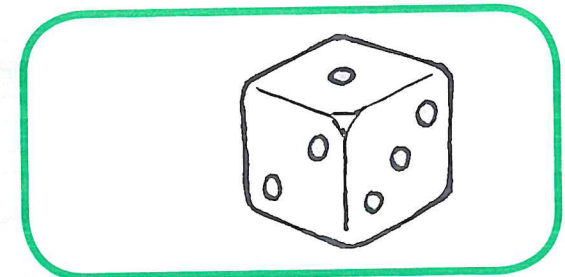

u



uti i uki ta un tiki tristu.
mama ula a trasha sopi
uster.
esta dushi, no?
pero unda mama ta?
uti i uki no por haña
kaminda di kas.
abo por yuda nan?
hala un liña
i mustra uti i uki,
unda nan tin ku kana.

wig

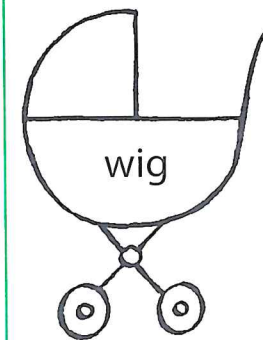
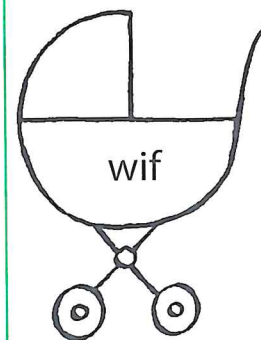
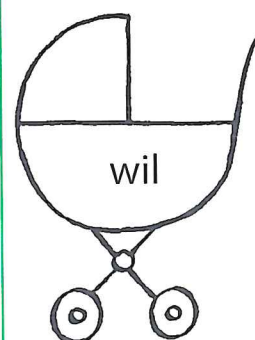
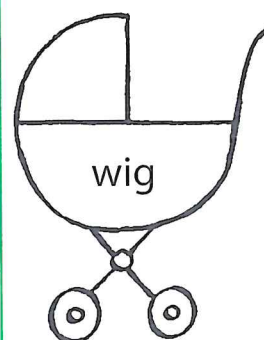
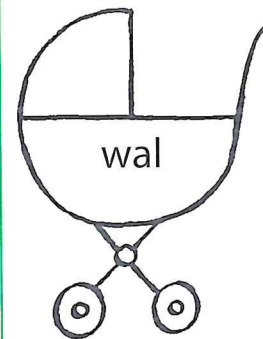
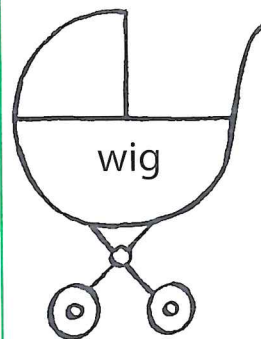
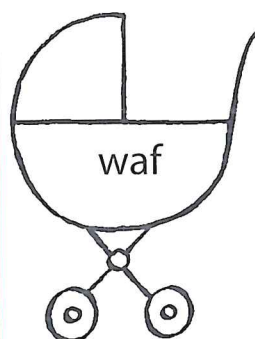
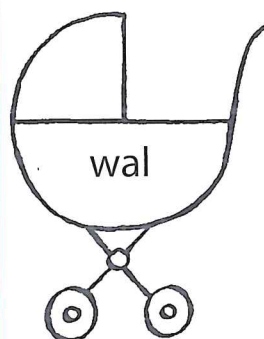
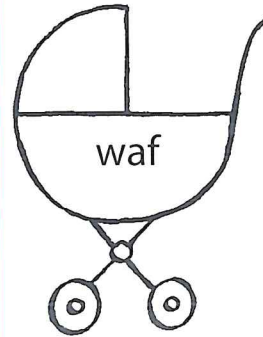
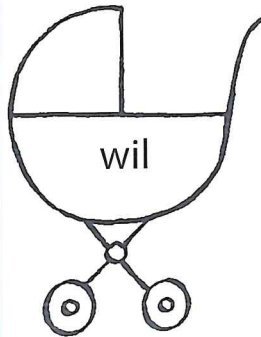
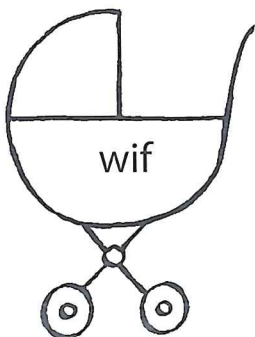
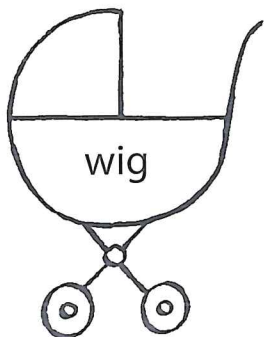

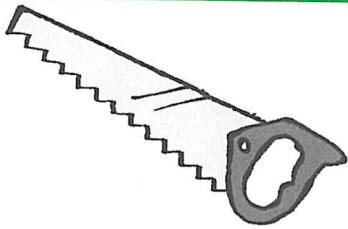
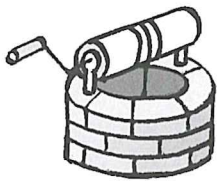
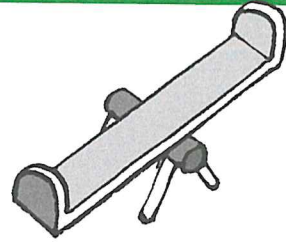
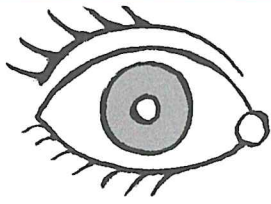

W

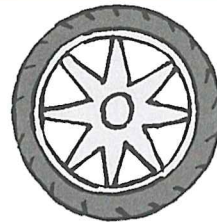

W



wita i waldo ta wep
wep, wap, tap, tep
ariba i abou
wela ta grita:
'wita i waldo,
tene kuidou!'

W

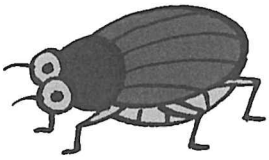
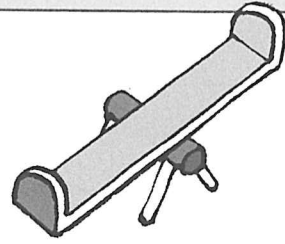
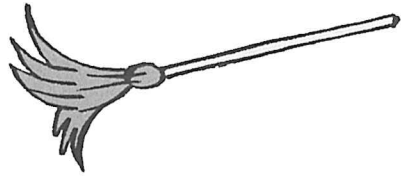
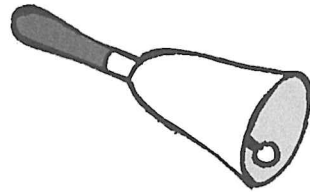
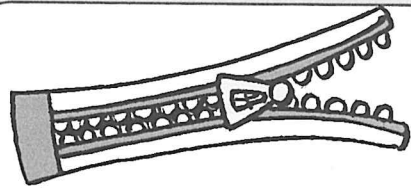
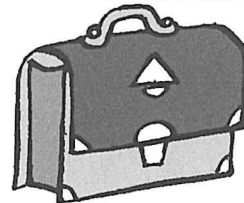
kas

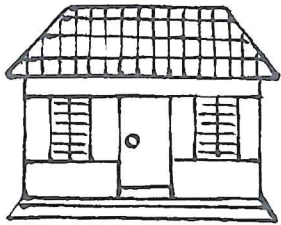

kos



kas

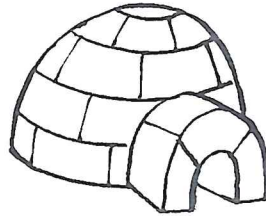

kam



kas

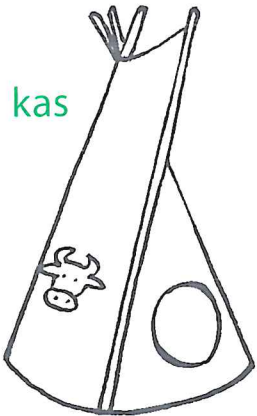

kas

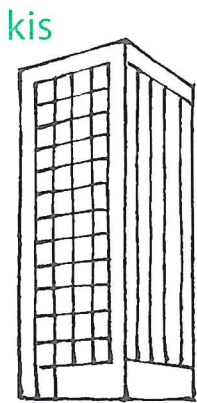

kis

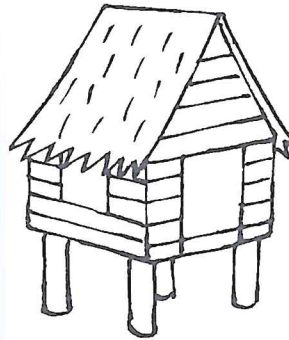

kam

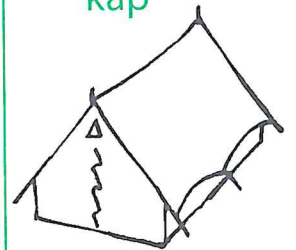

kap

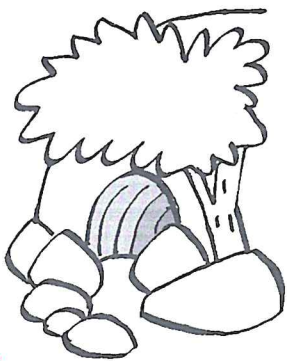

kis

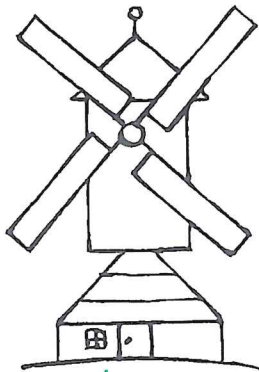

kap

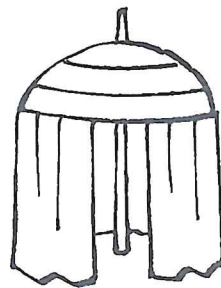

kas

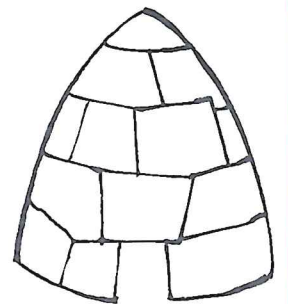

kos

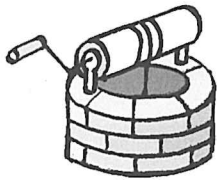
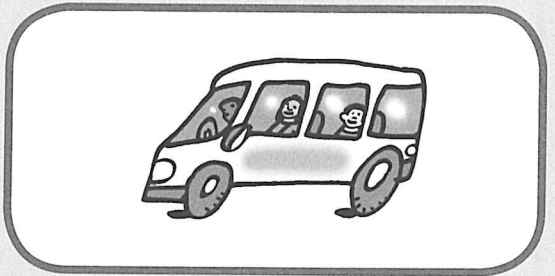
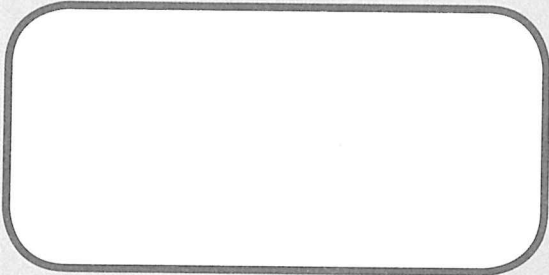
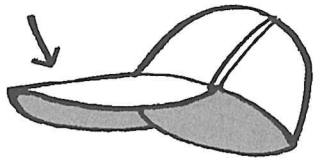

k

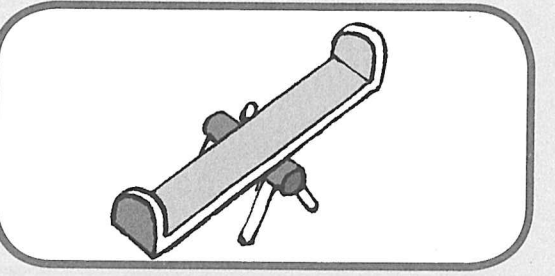
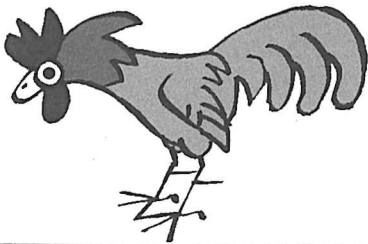
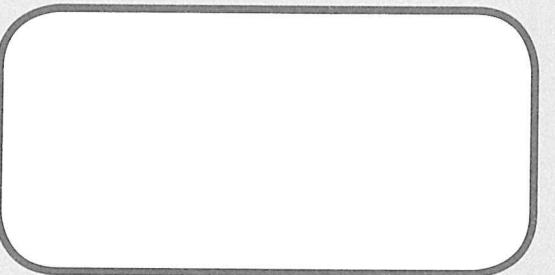
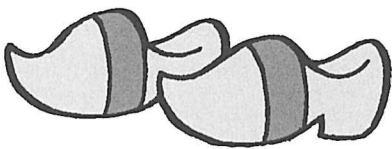
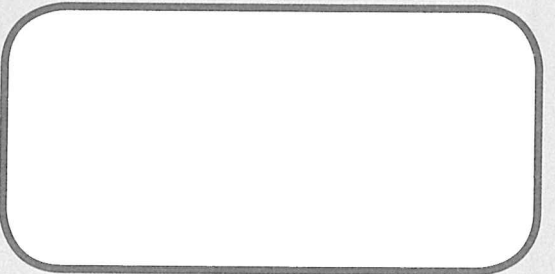

k

ko i ka dos krika
ta biba den un kas
den un palu diki
e palu di kalbas.

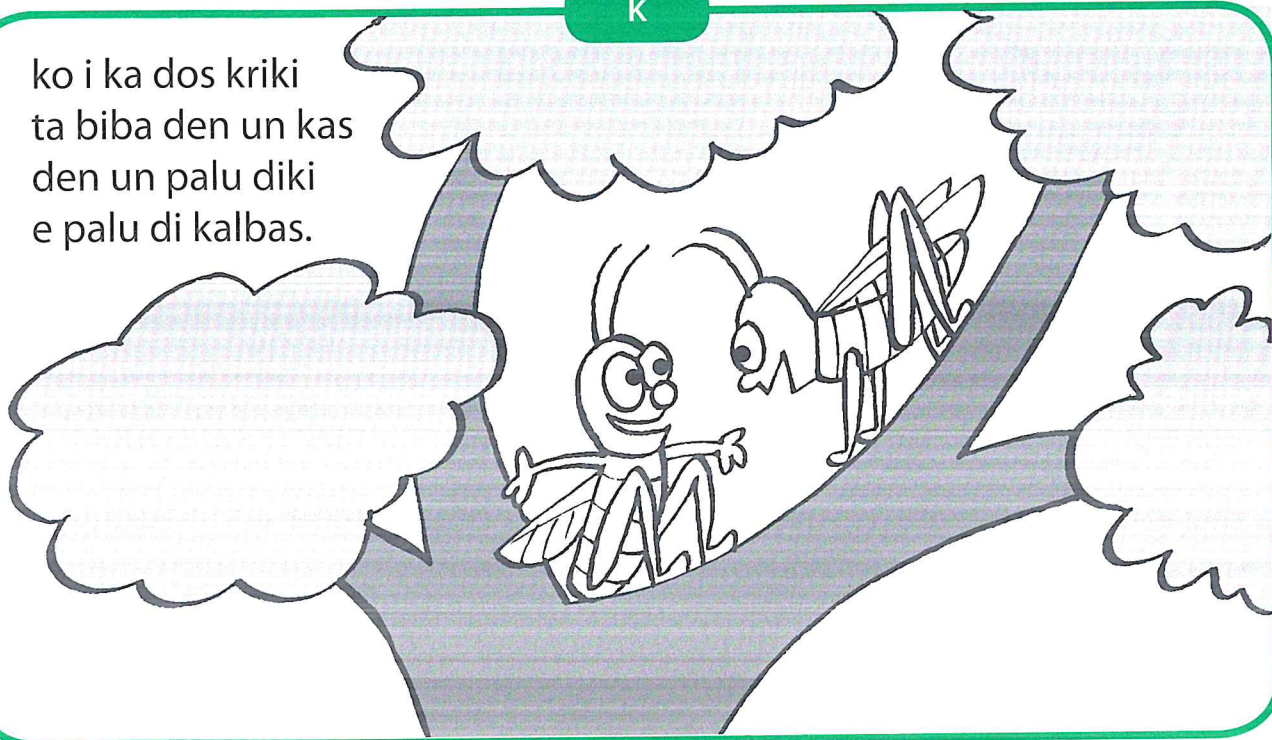

kiki i koko ta kome keshi
keshi komino i keshi raspá

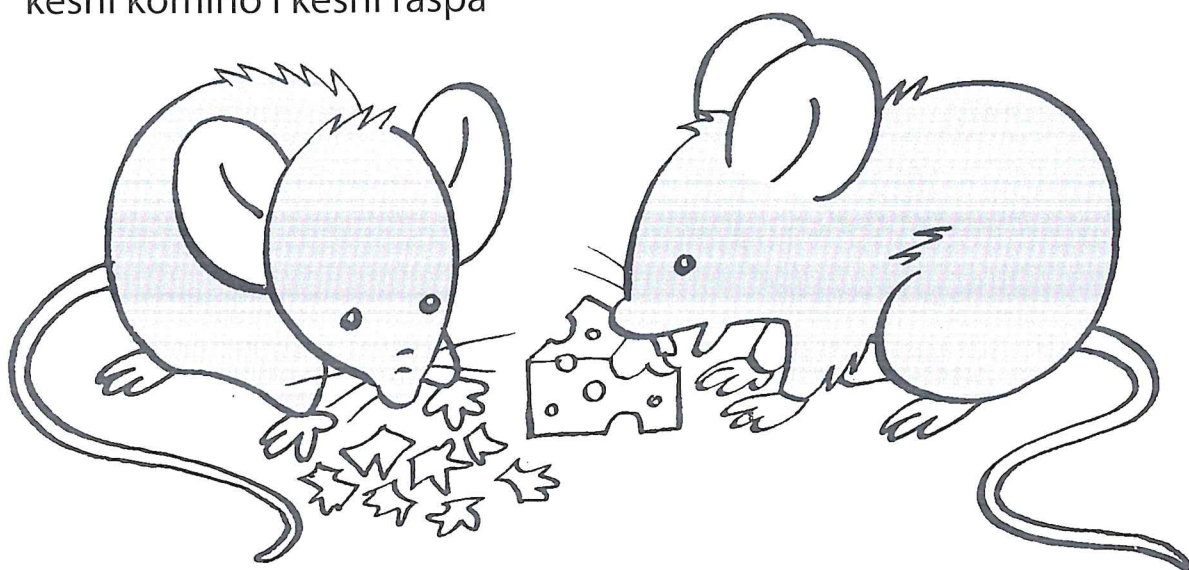

k

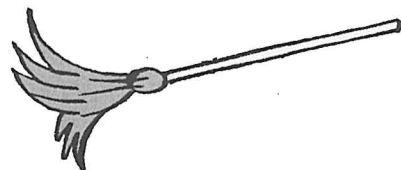
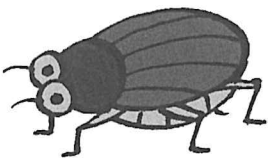
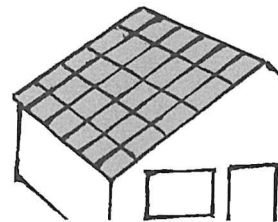
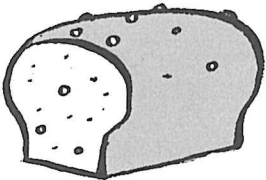
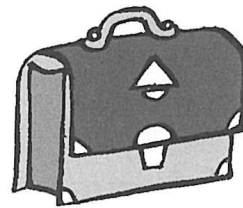
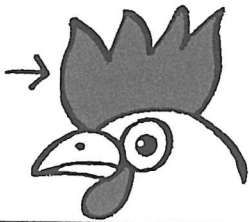

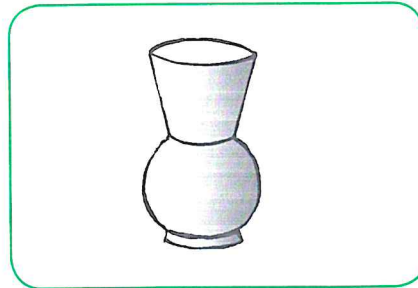
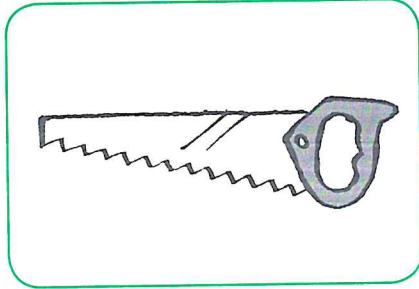
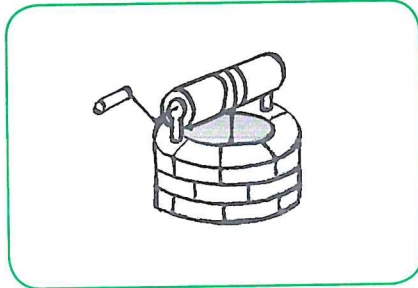
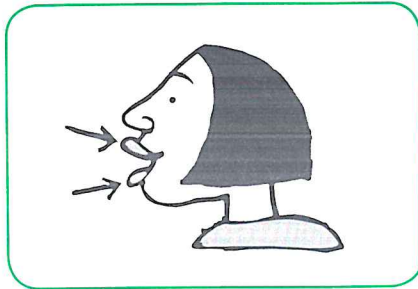
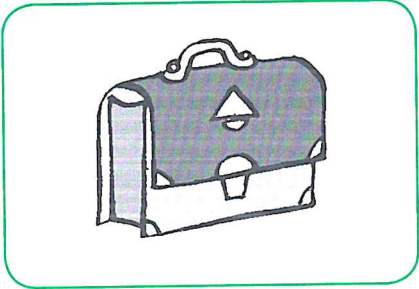
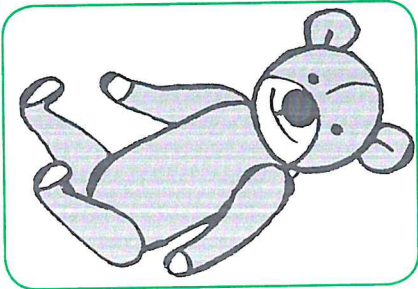
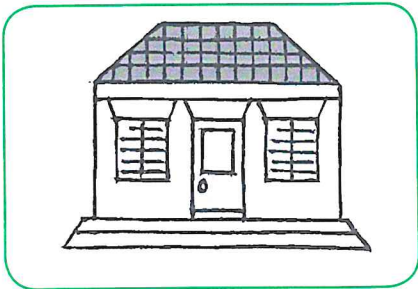

a

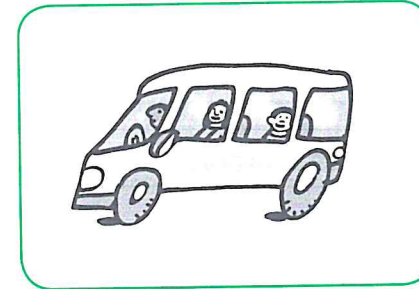
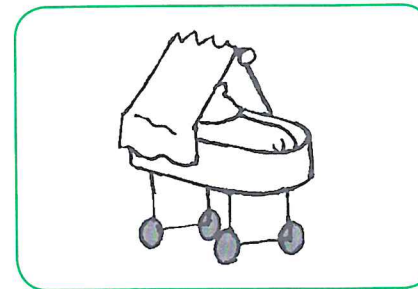
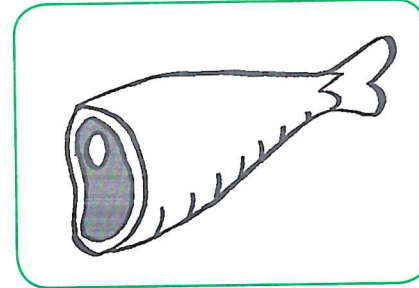
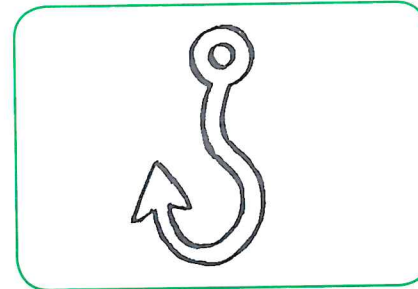
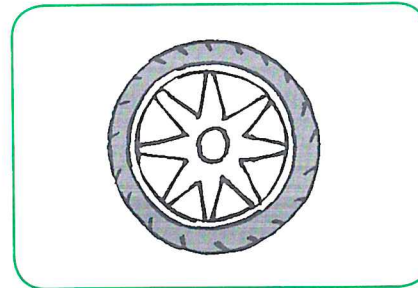
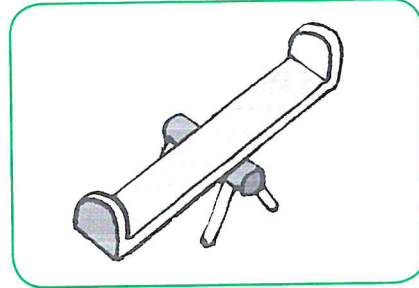

a



den toko di shon sam
nan ta bende ham
pan frances i pan buskuchi
mi ta kumpra pa e yuchi
fruta, keshi i hopi mas
mi ta hinka den mi tas.



a

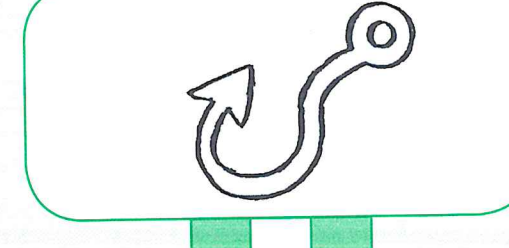
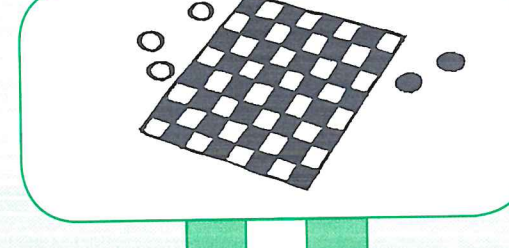
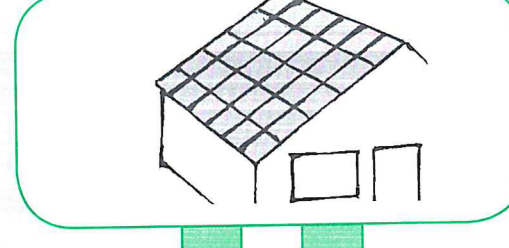
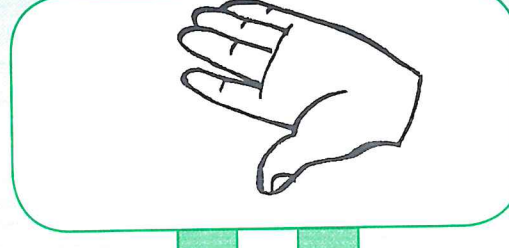
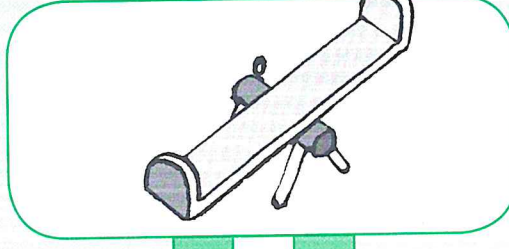
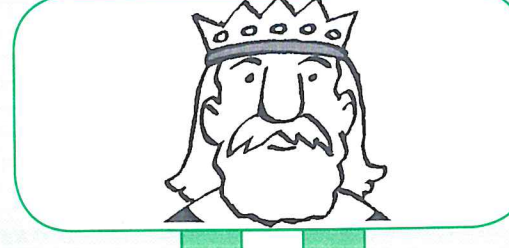
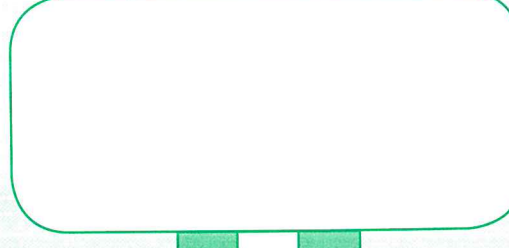
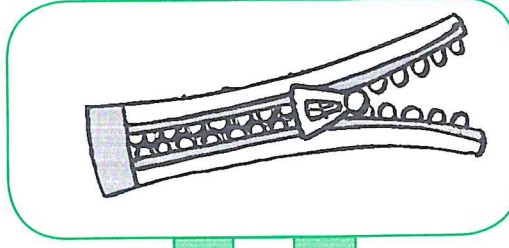
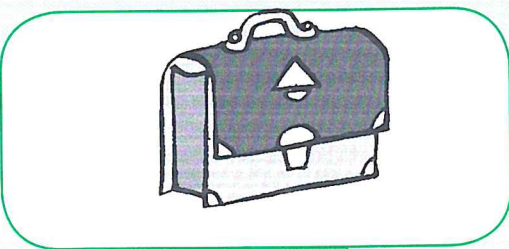

mama



mama	mimi	momo	meme
meme	mama	mimi	momo
mimi	meme	mama	mimi
momo	mimi	momo	mama

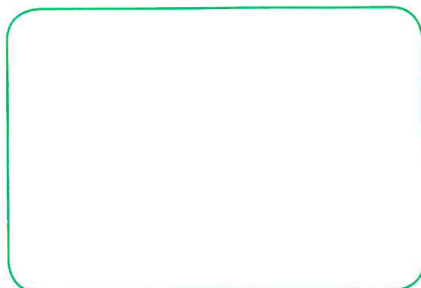
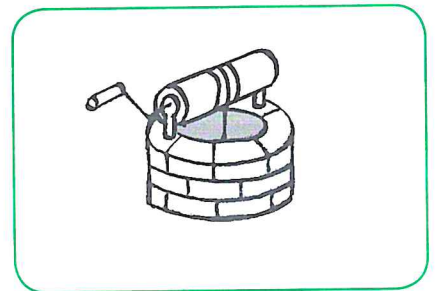
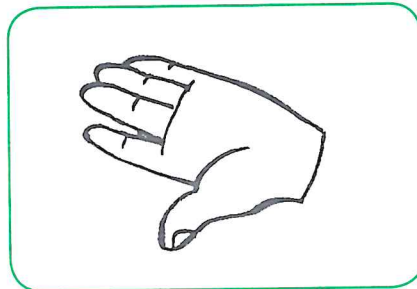
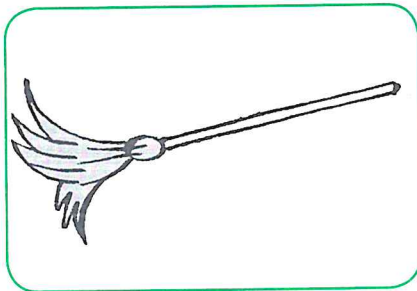

m

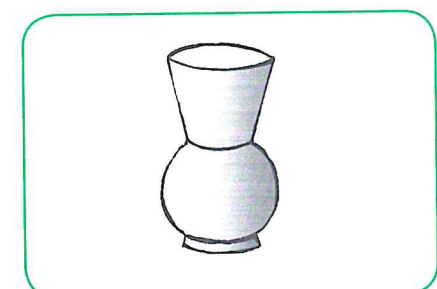
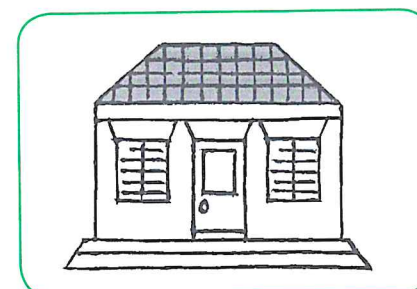
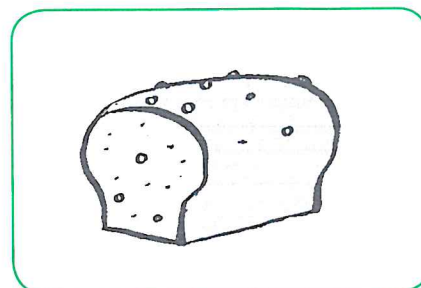
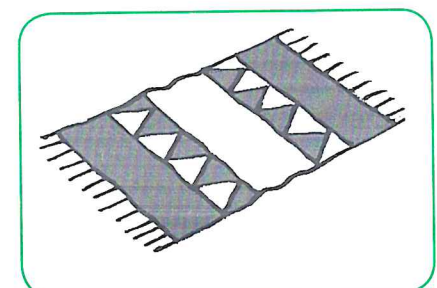
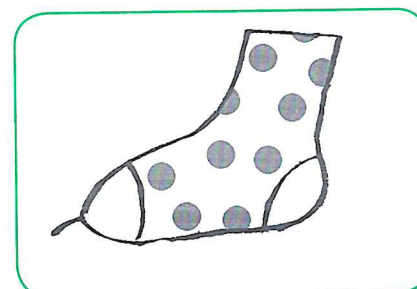
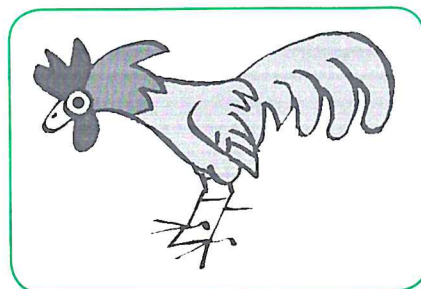
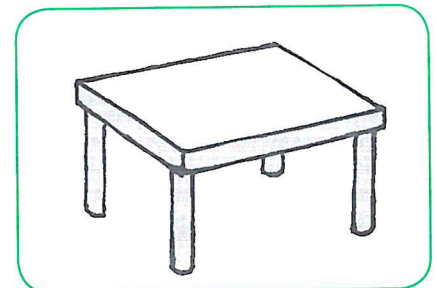

m



m ta di mama
maria e yama
m ta di mea
mi tin dos ku strea.

m ta di mata
mi gusta batata
m ta di mesa
ya mi por lesa.

m

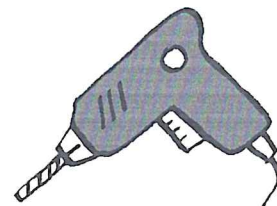
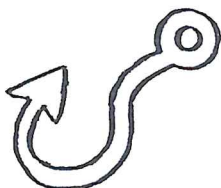
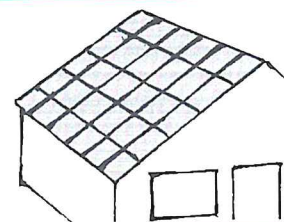
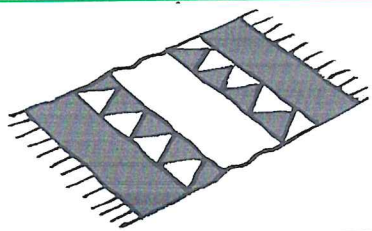
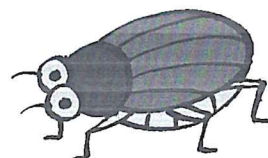
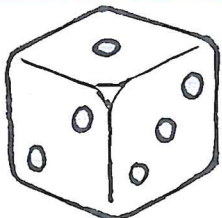
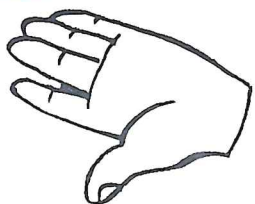
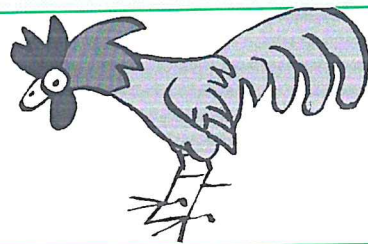
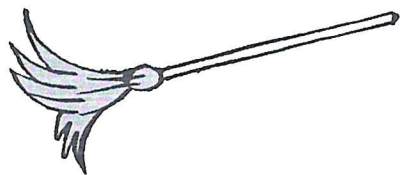

yu

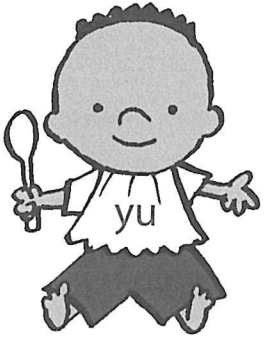

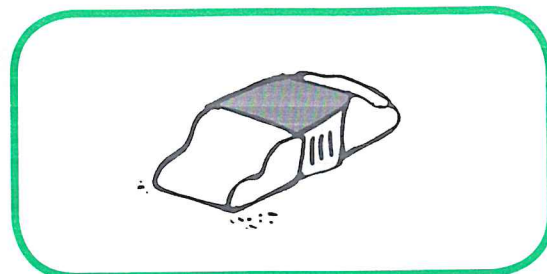
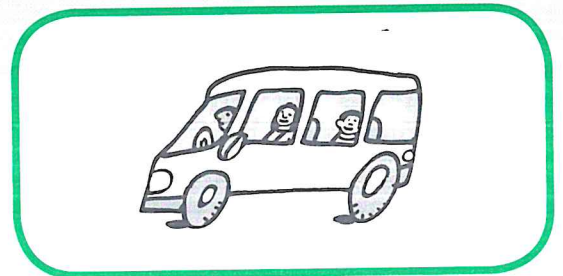
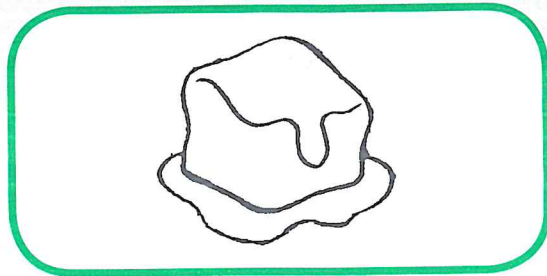
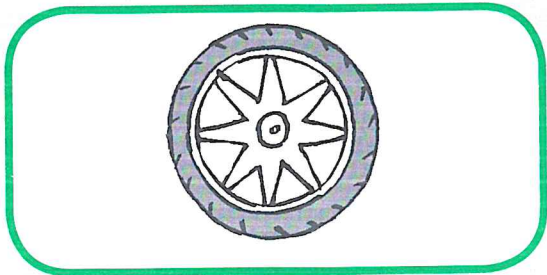

y

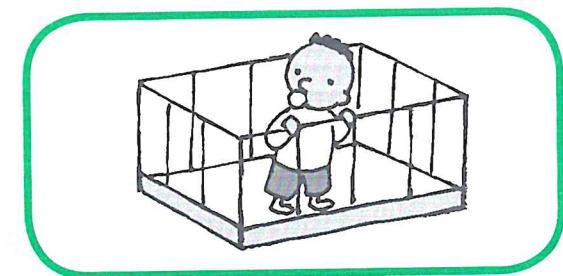
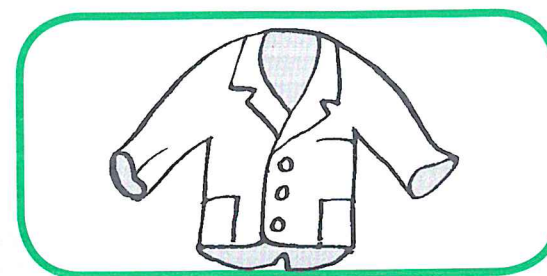
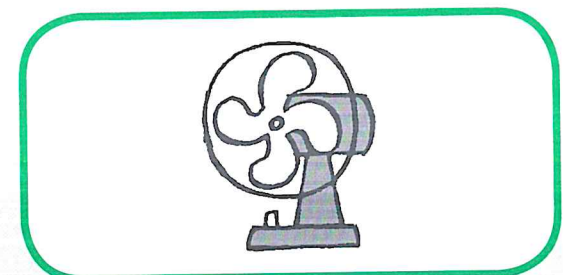
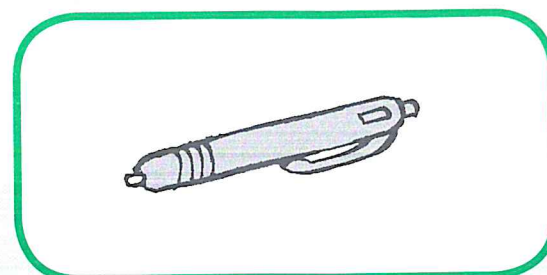
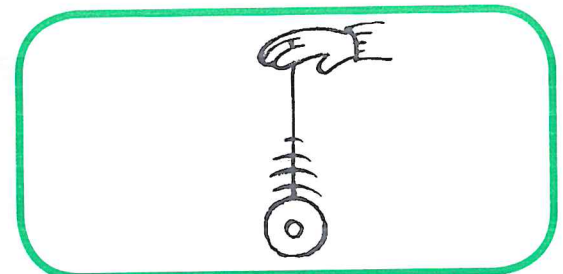

y



awa ta yobe
awa ta kai
yuchi ta yora
pa su mamai.

awa ta yobe
awa ta kai
yaya e yu
yay' é pa mamai

tata



tata	tawa	tutu	tipu
taki	tata	tipu	tutu
tipu	taki	tata	tutu
taki	tipu	tawa	tata

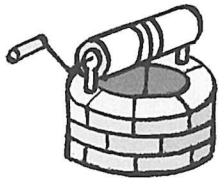
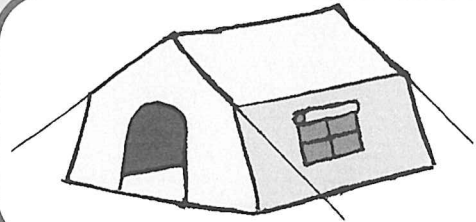
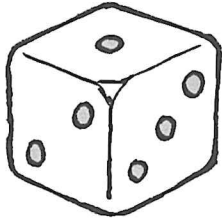

t

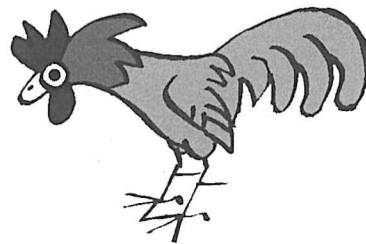
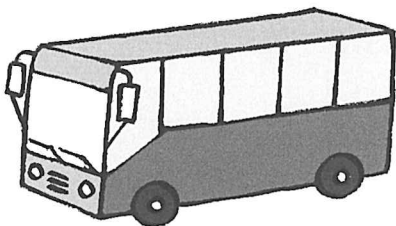
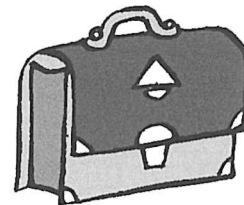
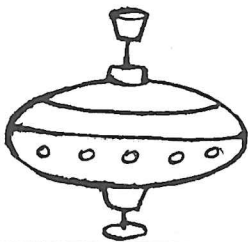

t

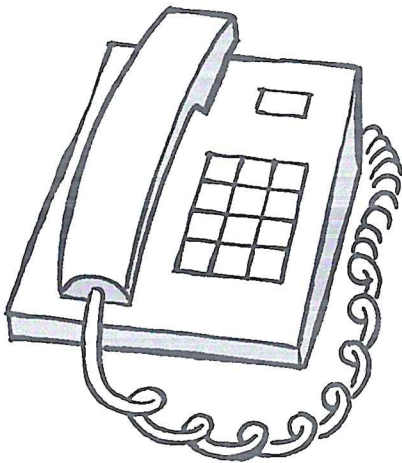
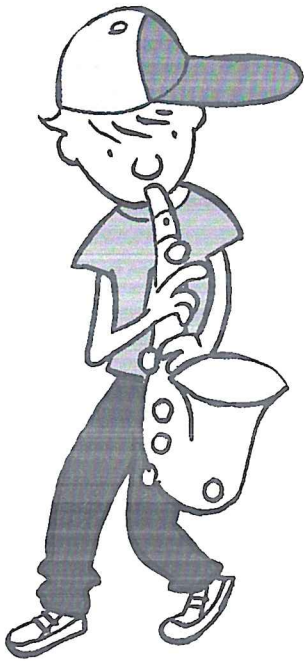

tròmpèt, tambú i saksofon,
e trio ta toka hopi bon.

trin, trin, ata telefòn ta rin
trin, trin, ta tio pa katrin

tomati, tamarein i patia
ta bende den toko di maria

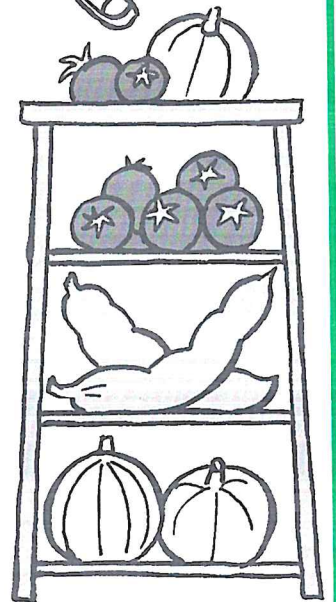

t

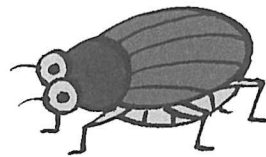
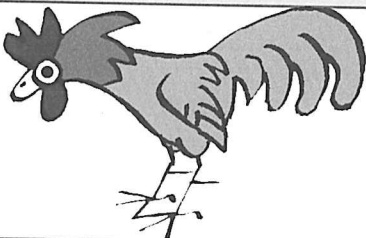
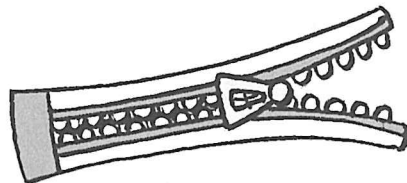
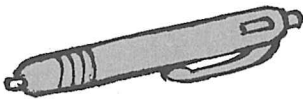
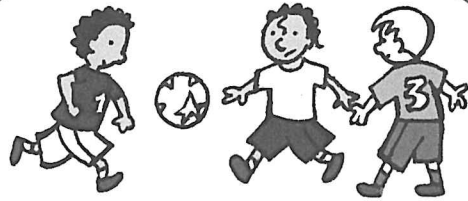
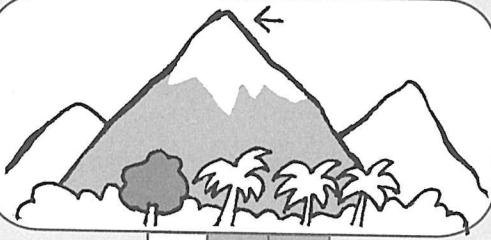
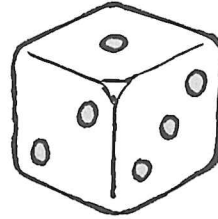
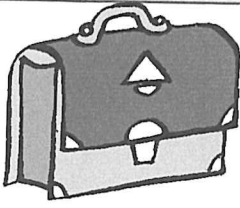

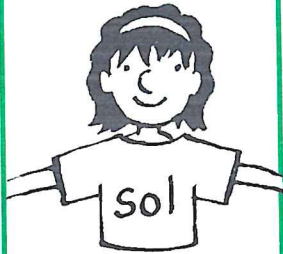

wig



sol

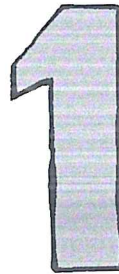

ber



un

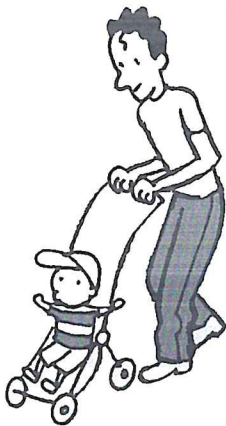

yu

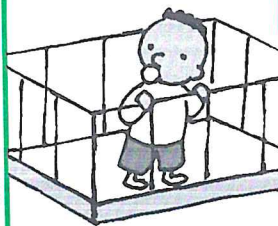

tata



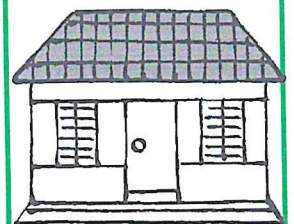

kas





mama



s

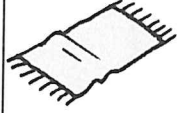

m

b



y

u

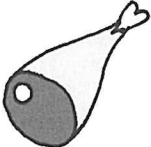
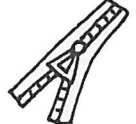

t

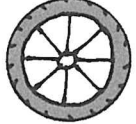
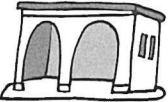

w

a

k



yu



mama



kas

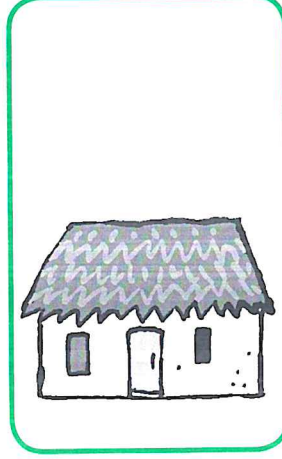

un

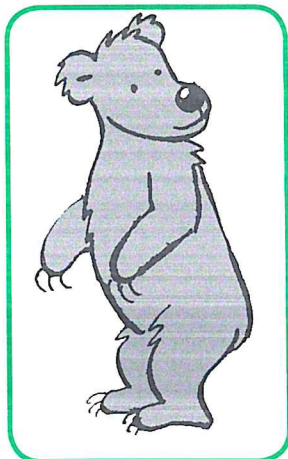

sol

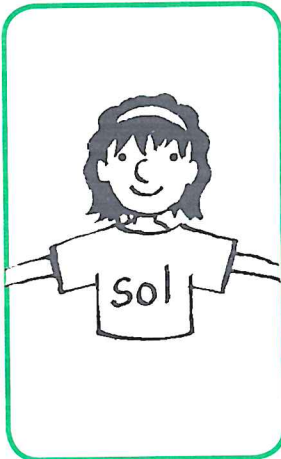

ber

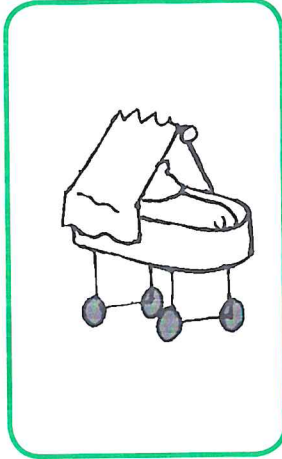



tata



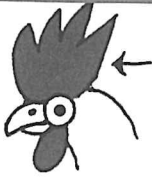

wig



s

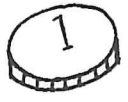

m



b

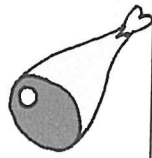

y

u



t

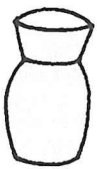
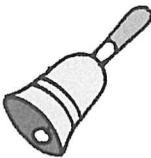
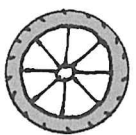

w

a

k



Método pa siña lesa na Papiamentu

buki di tarea 1

Tim di outor

Ronnie Şevering • Ria Severing-Halman
Mavis Ersilia • Ilona Berggraaf-Karsters
Karen Specht • Marelva Mathilda

Ilustrashon

Paul de Becker

Realisashon

Paul Dijkstra, Wietske Dijkstra

Salto, Buki di tarea 1
ISBN: 978-99904-2-246-7

© 2008 Fundashon pa Planifikashon di Idioma
Derecho reservá. No ta pèrmití pa reproduci nada di e edishon akí di ningun
forma, ni pa ningun medio, sin outorisashon previo i skibi di editor.



Fundashon pa
Planifikashon di
Idioma